

CLAMPS

FASTMILL
ZERO

MINI RANGE

VERTICAL
CLAMPING

MAGNETIC

THIRD POINT

RISERS

SPACERS

MODULES
AND PINS D49

MODULES
AND PINS D90

PLATES
AND BUSHES

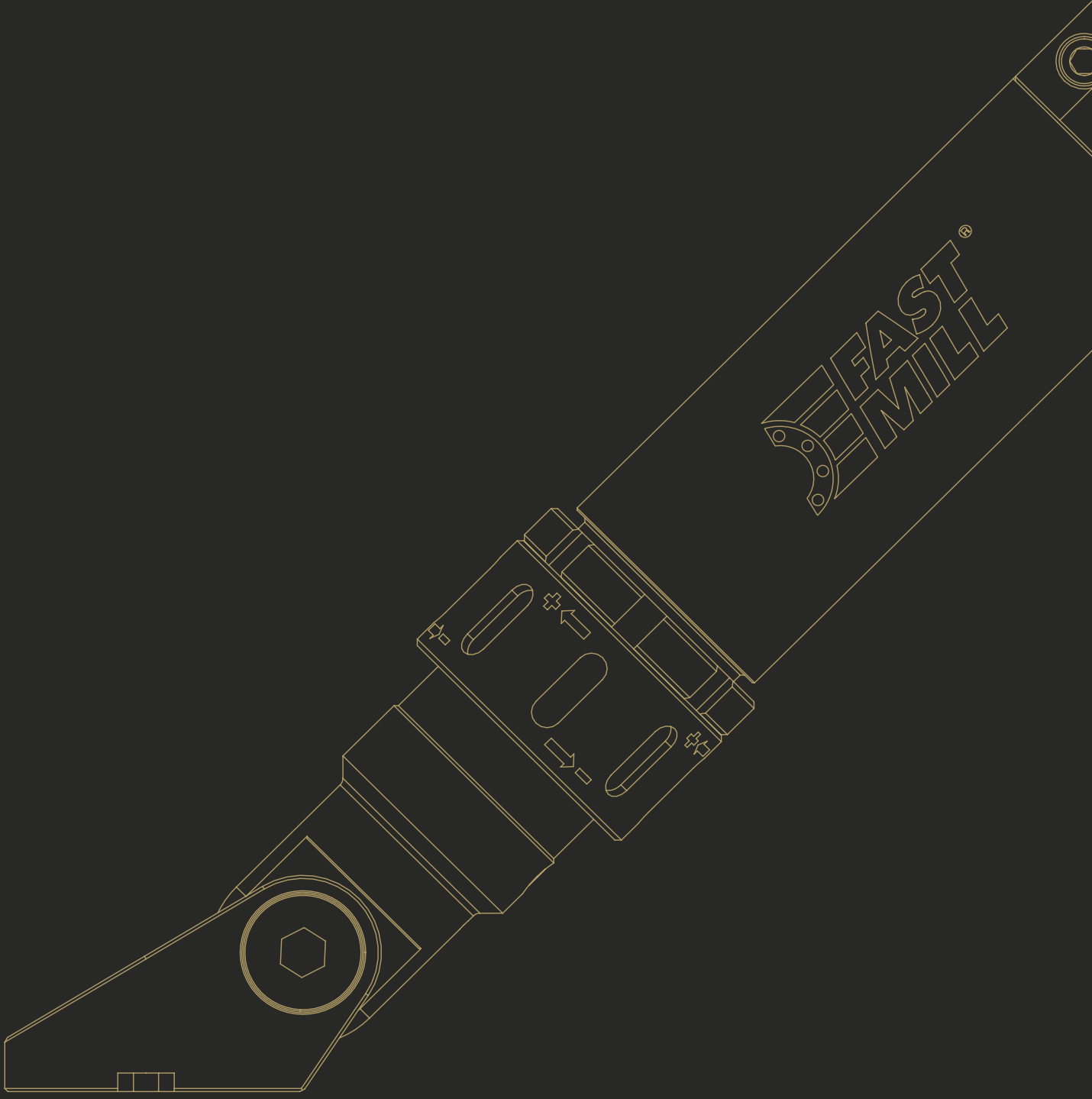

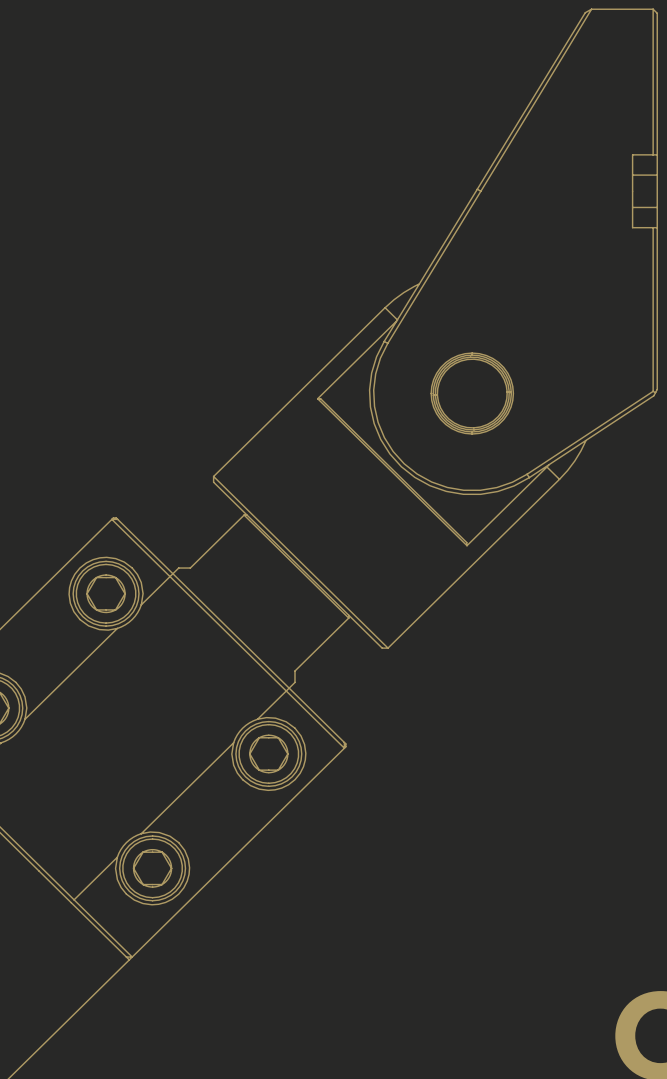

THIRD CLAMPING POINT



THIRD CLAMPING POINT SET

A third clamping point for roughing, finishing and drilling operations of pieces fixed in a vertical position. Thanks to its rigid telescopic system and its additional modular extensions, the third clamping point supports workpieces and opposes vibrations and flexures caused by machining operations, thus avoiding the use of expensive, heavy and bulky fastening brackets. The third clamping point can be fixed directly on plates or workpieces by means of standard TCEI screws or FASTMILL® coordinate modules/risers. Alternatively, it can be fixed on the machine's T-slots. In addition to fixing, thanks to its efficient fine adjustment system, it can be adjusted for the purposes of thrust or traction to ensure verticality of workpieces before their machining.

CODE	DESCRIPTION	DIMENSION
FM46191600	Third clamping point set	630/820 (24,80"/32,28")

SET CONFIGURATION	N°
Third clamping point	1 piece
C-hook spanner 92-95	1 piece
Bush Ø24-24 mm	2 pieces
Cylindrical head hexagon socket screw 12.9 (DIN912)	2 pieces

ACCESSORIES

CODE	DESCRIPTION	DIMENSION
FM46191650	Extension L=200	+ 200 (7,87")
FM46191656	Extension L=625	+ 625 (24,6")
FM46191659	Extension L=925	+ 925 (36,4")
FM93000019	C-hook spanner 92-95	

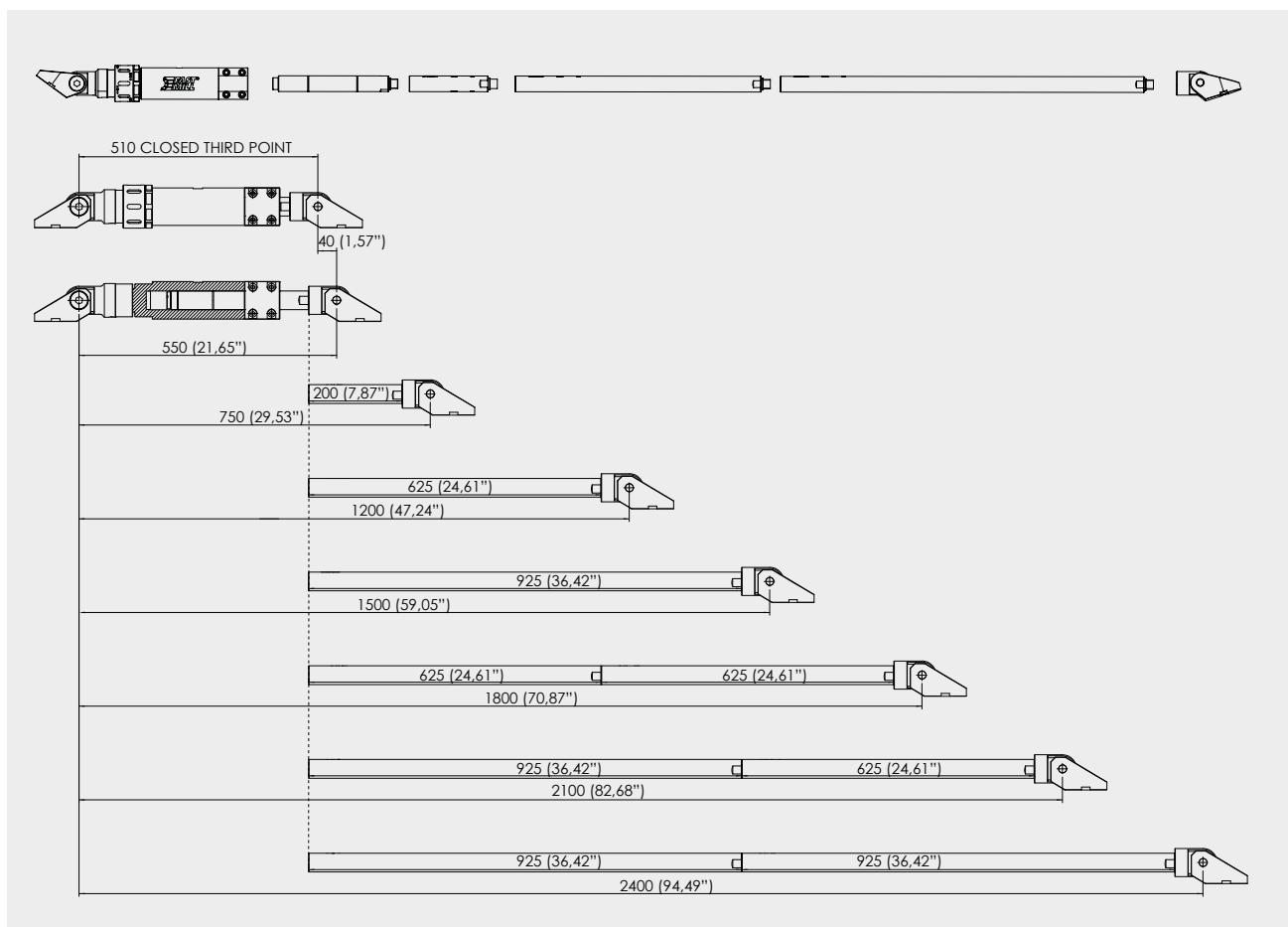

THIRD POINT LIGHT



The new third light point is a transversal component capable of absorbing vibrations in most applications. It is used for roughing, finishing, drilling operations on all those components that require greater support to avoid the triggering of unwanted vibrations. It is also used successfully in welded structures combined with FastMill magnetic systems. Its particular structure allows it to adapt to the desired length and then apply, if necessary, a pushing or pulling force on the workpiece using the threaded ring nut.

CODE	DESCRIPTION	DIMENSION	WEIGHT
FM46192500	Third clamping point light set	365/455 (14,37" / 17,9")	5 (11,02 lbs)

SET CONFIGURATION	N°
Third clamping point	1 piece
C - hook spanner 45	1 piece
Bush Ø24-24 mm	2 pieces
Cylindrical head hexagon socket screw 12.9 (DIN912)	2 pieces

ACCESSORIES

CODE	DESCRIPTION	DIMENSION
FM93000029	C - hook spanner 45	

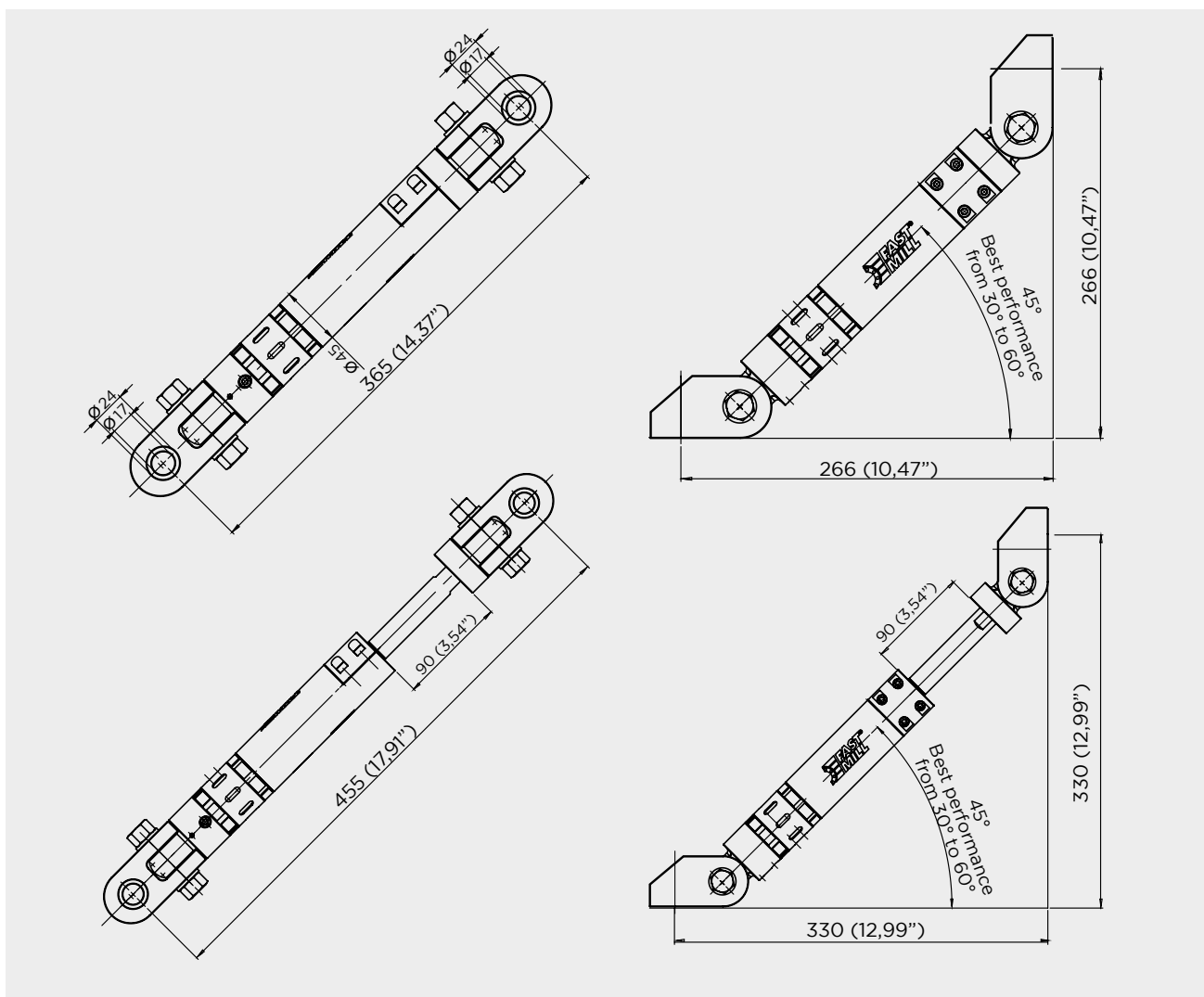

THIRD CLAMPING POINT SET

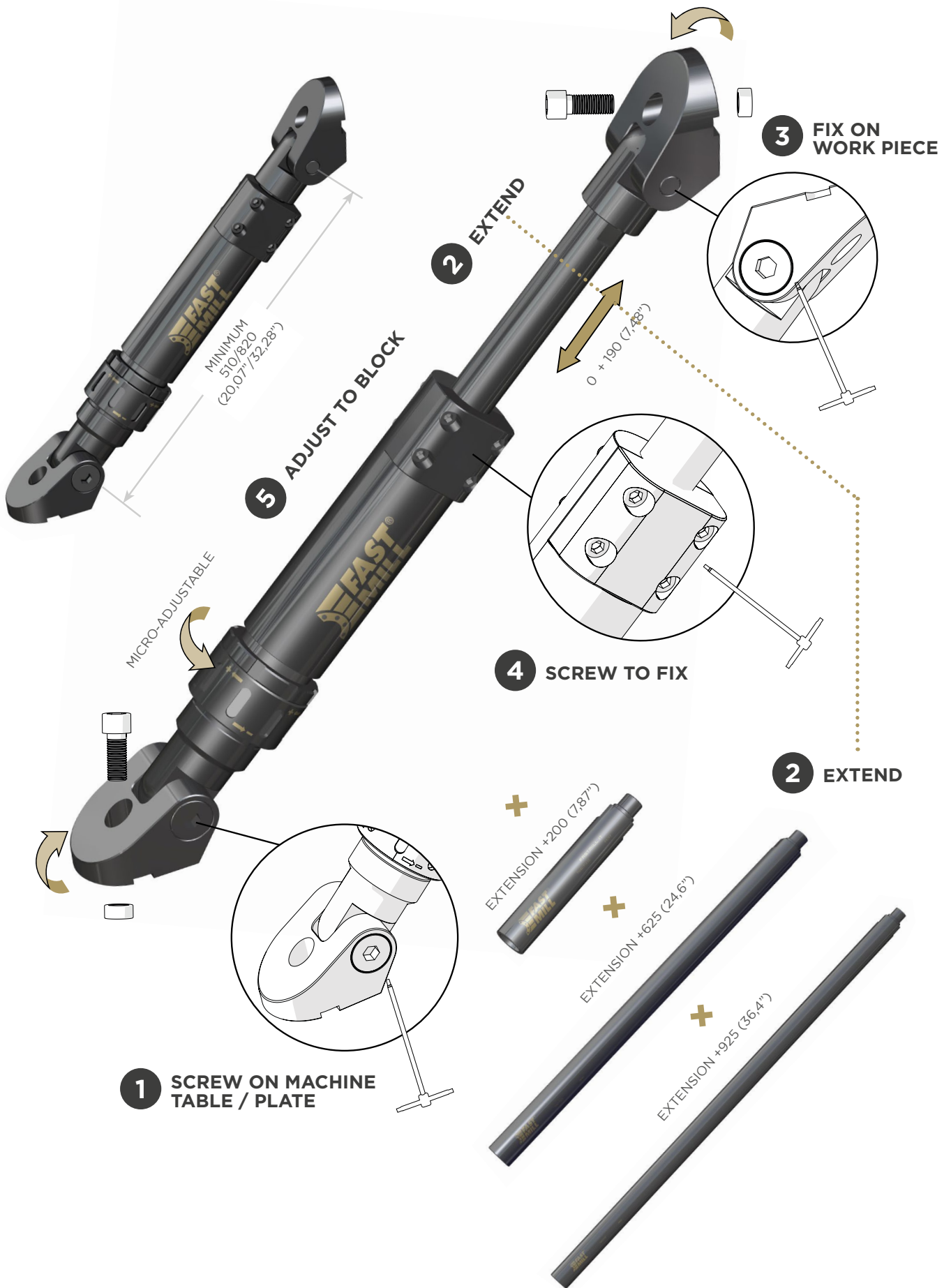

- CLAMPS
- FASTMILL ZERO
- MINI RANGE
- VERTICAL CLAMPING
- MAGNETIC
- THIRD POINT
- RISERS
- SPACERS
- MODULES AND PINS D49
- MODULES AND PINS D90
- PLATES AND BUSHES

SET UP EXAMPLE

- 1 SCREW ON MACHINE TABLE / PLATE
- 2 EXTEND
- 3 FIX ON WORK PIECE
- 4 SCREW TO FIX
- 5 ADJUST TO BLOCK

