



TILTING MODULE WITH 5° HIRTH TILTING MODULE WITH 10° HIRTH

The tilting module with incremental 5° or 10° pitch hirth allows you to convert the set up from 3 to multiple axes without repositioning the workpiece. Compact and extremely rigid, it guarantees maximum clamping dynamics.

CODE	DESCRIPTION	HEIGHT	Ø	ANGLE	WEIGHT
FMTMSS0590160	Tilting module with 5° hirth	160 (6,29")	96 (3,77")	5°	9,5 kg
FMTMSS1090120	Tilting module with 10° hirth	120 (4,72")	90 (3,54")	10°	4,8 (10,58 lbs)

CODE	DESCRIPTION	DIMENSION	HEIGHT	WEIGHT	PAG.
FMSLIDE030D90	Slide plate for Ø90 module	300x90 (11,81"x3,54")	30 (1,18")	5,1 (11,24 lbs)	44

TILTING MODULE WITH 5° HIRTH

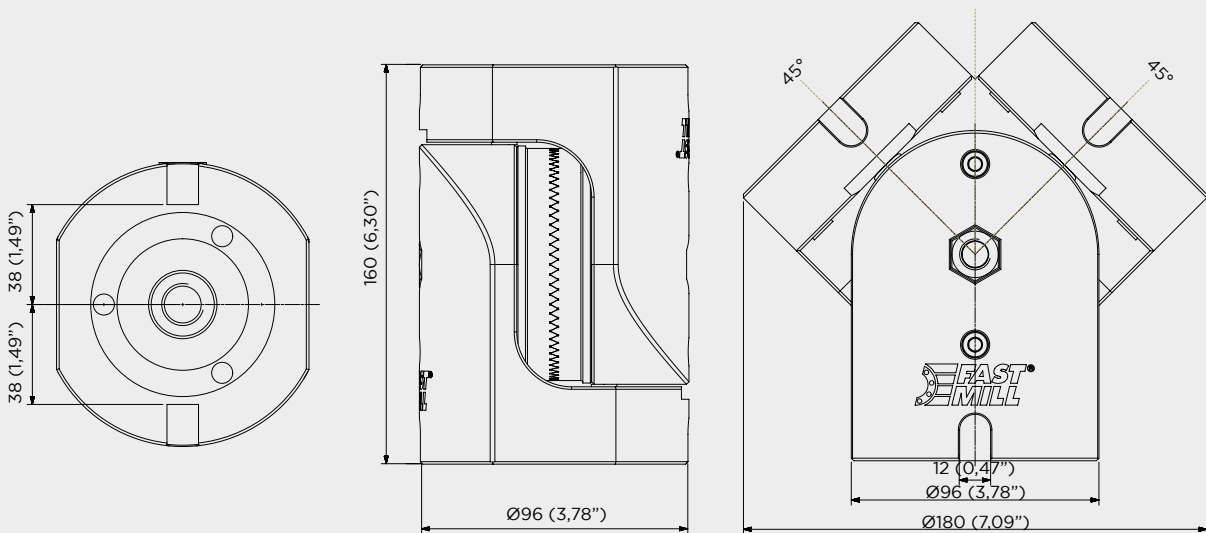

TILTING MODULE WITH 10° HIRTH

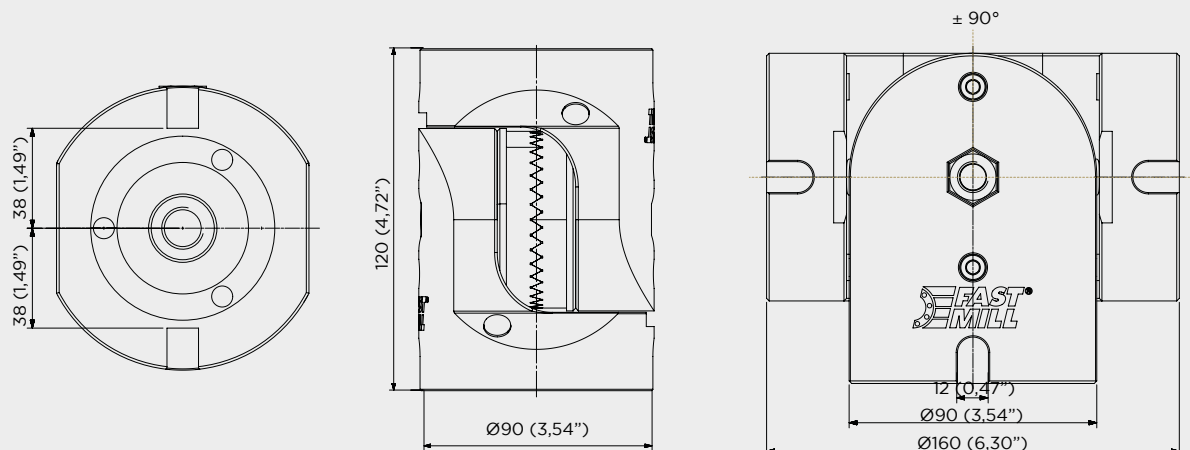

SETUP EXAMPLE 0°

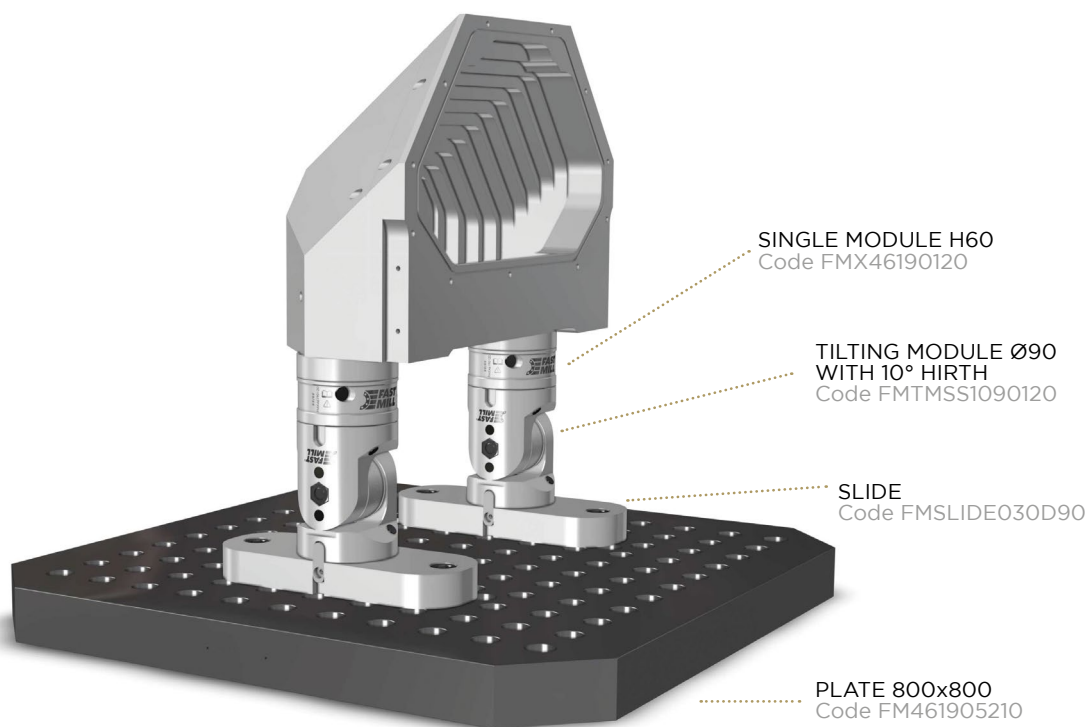

SETUP EXAMPLE 30°

