

**NEW**  
**PRODUCT!**

# APM00-RO

## Profiling Mills



ACHTECK launched its latest RO series profiling milling line, they are focused on Aerospace and Energy industry profiling cutting, such as Nickel base alloy, Titanium alloy and difficult to machine stainless steel. The latest proprietary patented PVD coating technology combined with 2 types geometry of MM3 and MR6, has outstanding performance and wide applicability

## ◆ Product Features

- Cutter diameter range from  $\Phi 25\text{mm}$  to  $\Phi 160\text{mm}$
- Multiple Chuck connection types: Screw connection interface, Cylinder shank and Arbor cutter
- Inserts has Anti-Rotation positioning function
- With MM3 geometry, fine ground flank and optimized cutting edge treatment, all these enable the cutter to have longer tool life
- New AP403S grade can fully cover Stainless Steel and Super Alloy machining

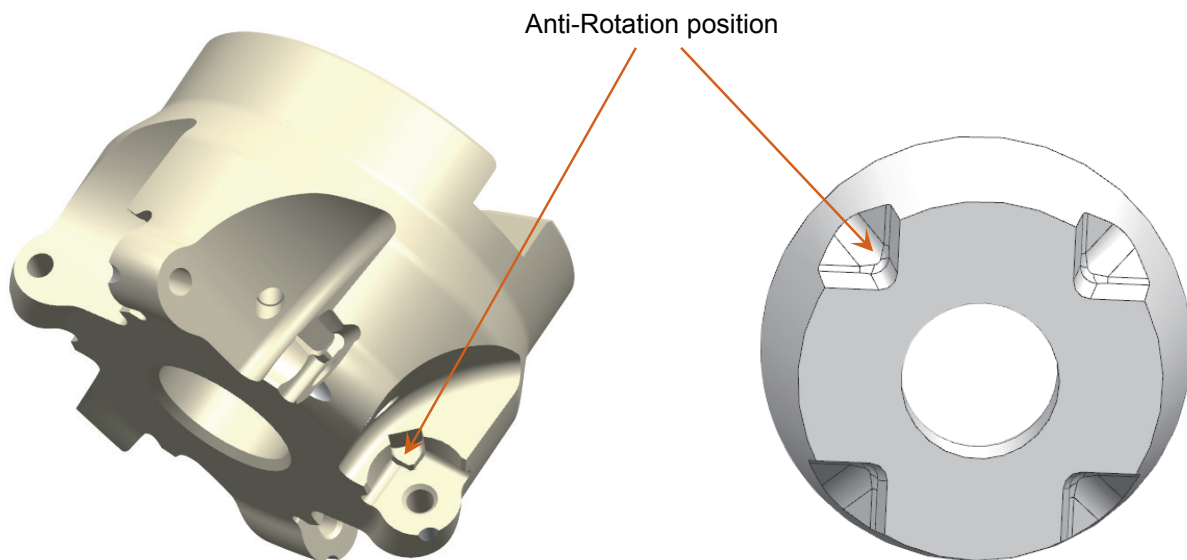

◆ **AP403S grade introduction**

AP403S is the preferred grade for Nickel base super Alloy milling, and also suitable for Titanium alloy and Stainless Steel milling.

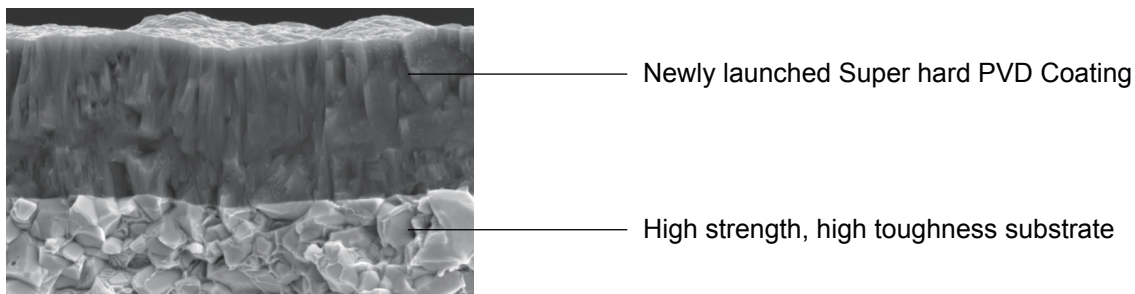

- Adopt material with high toughness and excellent high temperature resistant performance new substrate
- The usage of new generation PVD superhard coating, have super smooth surface, low friction coefficient features
- It still maintains good impact resistance and high cutting tool life even under complex and harsh working conditions such as strong impact and serious oxidation workpiece

◆ **Grades introduction and application range recommendation**

Grade	Coating	Material					
		P	M	K	S	N	H
AP403S	PVD		●		●		

● Marked : 1<sup>st</sup> Choice   ● Marked : 2<sup>nd</sup> Choice   ○ Marked : Supplementary application

◆ **Geometry Introduction**

Geometry	Cutting Edge Shapes	Application conditions recommended
<b>MM3</b>		<ul style="list-style-type: none"> <li>• Sharp</li> <li>• Relatively good working condition</li> <li>• Low cutting force (suitable for low power machine condition)</li> <li>• Medium feed rate</li> </ul>
<b>MR6</b>		<ul style="list-style-type: none"> <li>• Strong</li> <li>• For poor operating conditions</li> <li>• Highest machining stability</li> <li>• Higher feed rate</li> </ul>

• **Case Study**

Workpiece: Turbine blade

Materials: X12CrNiMoV12-2

**Inserts: ROMT 1204M6E-MR6 AP403S**

Cutter: APM00-040-Z04-A16R-RO12-C

Machining process name: Airfoil roughing

Cutting parameters:  $V_c=198\text{m/min}$ ,  $f_z=0.25\text{mm/z}$ ,  $a_p=1.5\text{mm}$

Coolant supply: yes

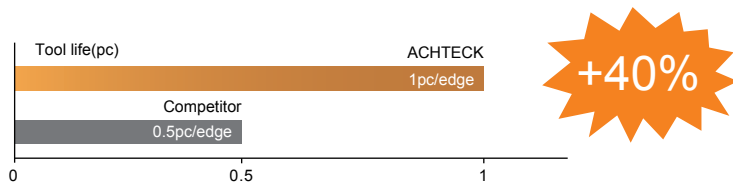

Workpiece: Aircraft landing gear

Materials: Ti5553

**Insert: ROHT 1204M4E-MM3 AP403S**

Cutter: APM00-063-Z06-A22R-RO12-C

Machining process: Face Milling

Cutting parameters:  $V_c=30\text{m/min}$ ,  $f_z=0.3\text{mm/z}$ ,  $a_p=1.5\text{mm}$

Coolant supply: yes

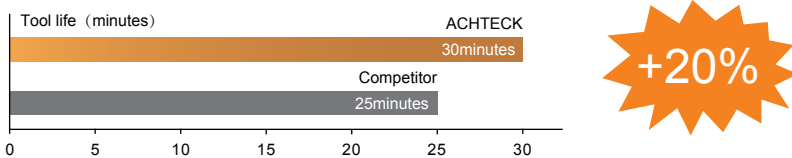
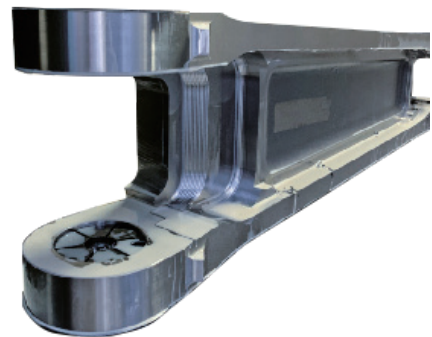

● **Inserts Stock Status**

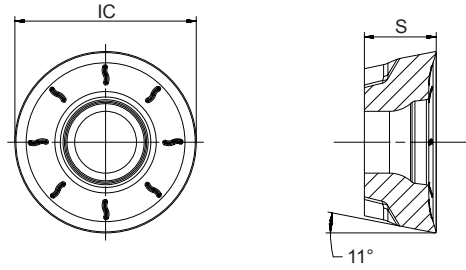

Inserts	Model	Size		Grades						
		IC	S	CVD coated		PVD coated			Uncoated	
				AC301P	AC301K	AP301U	AP351U	AP401M	AP403S	AW100K
	ROHT 0803M0E-MM3	08	3.18						●	
	ROHT 10T3M8E-MM3	10	3.97						●	
	ROHT 1204M4E-MM3	12	4.76						●	
	ROHT 1204M6E-MM3	12	4.76						●	
	ROHT 1605M8E-MM3	16	5.56						●	
	ROHT 2006M8E-MM3	20	6.35						●	

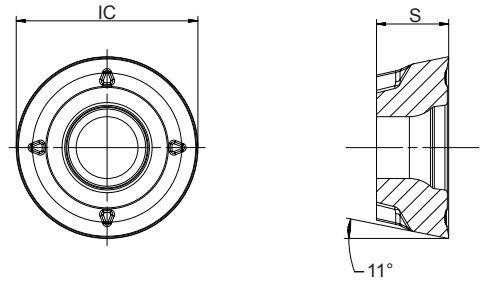

Inserts	Model	Size		Grades						
		IC	S	CVD coated		PVD coated			Uncoated	
				AC301P	AC301K	AP301U	AP351U	AP401M	AP403S	AW100K
	ROMT 10T3M4E-MR6	10	3.97						●	
	ROMT 1204M6E-MR6	12	4.76						●	
	ROMT 1605M6E-MR6	16	5.56						●	
	ROMT 2006M8E-MR6	20	6.35						●	

● 代表常规库存

APM00-RO Cylinder shank holder

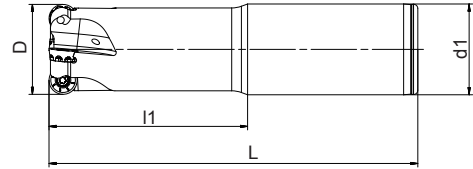
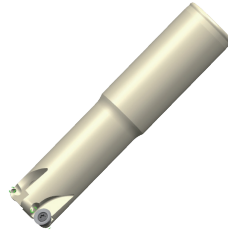
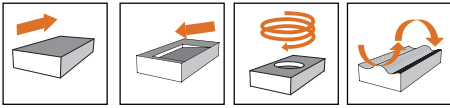

Designation	Dimension					Coolant	Z	Insert
	D	d1	L	l1	apmax			
APM00-025-Z04-C25R-RO08-L116-C	25	25	116	60	4		4	RO 08
APM00-025-Z03-C25R-RO10-L225-C	25	25	225	60	5		3	RO 10
APM00-032-Z04-C32R-RO10-L130-C	32	32	130	70	5		4	
APM00-032-Z03-C32R-RO12-L120-C	32	32	120	40	6		3	RO 12

APM00-RO Screw type holder

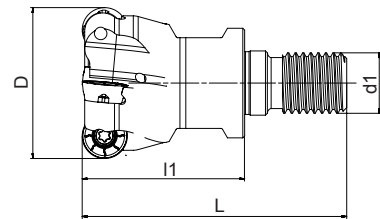
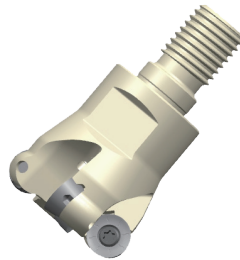
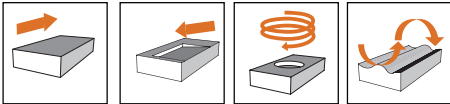

Designation	Dimension					Coolant	Z	Insert
	D	d1	L	l1	apmax			
APM00-025-Z03-M12R-RO10-C	25	M12	59	35	5		3	RO 10
APM00-032-Z04-M16R-RO10-C	32	M16	70	43	5		4	
APM00-040-Z04-M16R-RO12-C	40	M16	70	43	6		4	RO 12

Remark: represent for coolant  
 represent for no coolant

APM00-R020 Arbor type cutter

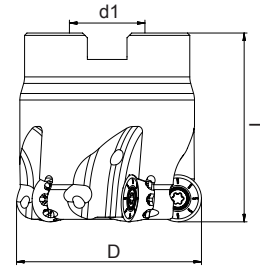
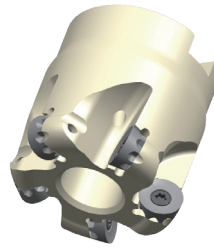
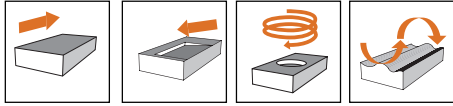

Designation	Dimension					Coolant	Z	Insert
	D	d1	L	l1	apmax			
APM00-040-Z05-A16R-RO10-C	40	16	40	-	5		5	RO 10
APM00-050-Z06-A22R-RO10-C	50	22	40	-	5		6	
APM00-040-Z04-A16R-RO12-C	40	16	40	-	6		4	RO 12
APM00-050-Z05-A22R-RO12-C	50	22	40	-	6		5	
APM00-063-Z06-A22R-RO12-C	63	22	40	-	6		6	
APM00-080-Z07-A27R-RO12-C	80	27	50	-	6		7	RO 16
APM00-063-Z05-A22R-RO16-C	63	22	40	-	8		5	
APM00-080-Z06-A27R-RO16-C	80	27	50	-	8		6	
APM00-100-Z07-A32R-RO16-C	100	32	50	-	8		7	RO 20
APM00-100-Z06-A32R-RO20-C	100	32	50	-	10		6	
APM00-125-Z07-A40R-RO20-C	125	40	63	-	10		7	
APM00-160-Z08-A40R-RO20	160	40	63	-	10		8	

Remark: represent for coolant  
 represent for no coolant

◆ Spare parts Accessories

Spare Parts	Inserts Model	RO.T 0803	RO.T 10T3	RO.T 1204	RO.T 1605	RO.T 2006
	Tightening Screw	SP030062	SP030072H	SP040085H	SP050120	SP060121
	Tightening torque	2.0Nm	2.0Nm	4.0Nm	5.0Nm	7.0Nm

Appendices	Inserts Model	RO.T 0803		RO.T 10T3		RO.T 1204		RO.T 1605	RO.T 2006
	Screw Wrench	DT-TP09		DT-TP09		DT-TP15		DT-TP20	DT-TP25
			Cutter head installation wrench	φ20	AFW-15	φ25	AFW-19	φ40	AFW-24
φ32	AFW-24								

● **Shank Stock models(for Screw types cutter)**

1-Head taper structure

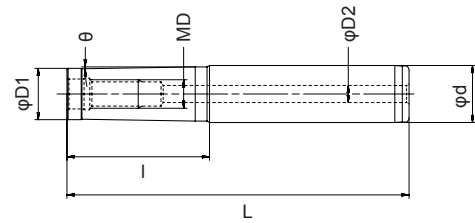

Designation	Dimension						materials
	MD	φd	φD1	φD2	L	l	
AMS-M10-030-100-20T	M10	20	18	6	100	30	Steel
AMS-M10-050-120-20T	M10	20	18	6	120	50	Steel
AMC-M10-090-150-20T	M10	20	18	6	150	90	Carbide
AMC-M10-140-200-20T	M10	20	18	6	200	140	Carbide
AMS-M12-030-110-25T	M12	25	22.5	6	110	30	Steel
AMS-M12-050-130-25T	M12	25	22.5	6	130	50	Steel
AMC-M12-120-180-25T	M12	25	22.5	6	180	120	Carbide
AMC-M12-140-250-25T	M12	25	22.5	6	250	140	Carbide
AMS-M16-035-125-32T	M16	32	28.5	8	125	35	Steel
AMS-M16-055-145-32T	M16	32	28.5	8	145	55	Steel
AMC-M16-120-200-32T	M16	32	28.5	8	200	120	Carbide
AMC-M16-180-260-32T	M16	32	28.5	8	260	180	Carbide

2-Straight Shank

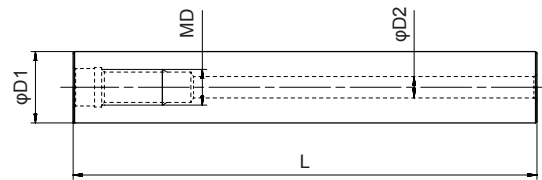

Designation	Dimension				materials
	MD	φD1	φD2	L	
AMC-M10-130-20S	M10	20	6	130	Carbide
AMC-M10-250-20S	M10	20	6	250	Carbide
AMC-M12-145-25S	M12	25	6	145	Carbide
AMC-M12-285-25S	M12	25	6	285	Carbide
AMC-M16-157-32S	M16	32	8	157	Carbide
AMC-M16-287-32S	M16	32	8	287	Carbide

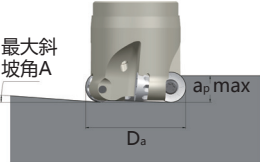

• **Ramping Milling parameters**

Ramping	Da ( mm )	Maximum angle A ( ° )				
		Indexible inserts diameter d ( mm )				
		d8	d10	d12	d16	d20
	25	3.2	6.5			
	32		3.0	4.2		
	40		1.4	3.0		
	50		2.0	2.1		
	63			1.5	2.6	
	80			1.4	1.4	
	100				1.0	1.3
	125					0.9
	160					0.7
	ap max(mm)	6.6	8.8	10.7	14	17.2

• **Helical Ramping Milling parameters**

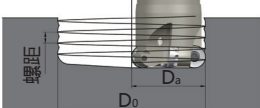
Actual Helical Ramping data on workpiece	Da ( mm )	Diameter range of the hole that can be milled by one pass ( mm )									
		Indexible inserts diameter d ( mm )									
		d8		d10		d12		d16		d20	
		DO min (mm)	DO max (mm)	DO min (mm)	DO max (mm)	DO min (mm)	DO max (mm)	DO min (mm)	DO max (mm)	DO min (mm)	DO max (mm)
	25	36.5	50	32	50						
	32			46	64	42.5	64				
	40			62	80	59	80				
	50			82	100	78.5	100	97.5	126		
	63					104.5	126	131.5	160		
	80					138	160	171.5	200		
	100									165.5	200
	125									215.5	250
	160									285.5	320

● **Cutting data Recommended**

Machined Materials		Achteck Milling Application Ranges		Cutting depth and feed																													
ISO	Machined Materials	Tensile strength (N/mm <sup>2</sup> )	Hardness (HB)	AP403S		PVD		M30-40		S30-40		-		-		øe/Dc		1/10		1/5		1/1											
				APM00-RO08	APM00-RO10	APM00-RO12	APM00-RO16	APM00-RO20	MM3	MM6	MM3	MM6	MM3	MM6	MM3	MM6	MM3	MM6	MM3	MM6	MM3	MM6	MM3	MM6	MM3	MM6							
				Cutter diameter		apmax		Geometry		Feed(mm/z)																							
				φ25		φ25-φ50		φ63-φ100		φ100-φ160		4		5		6		8		10													