

# Side Lock para Brocas

Para brocas de inserción.

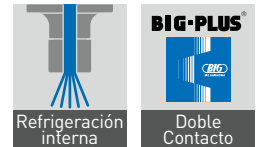

A.1

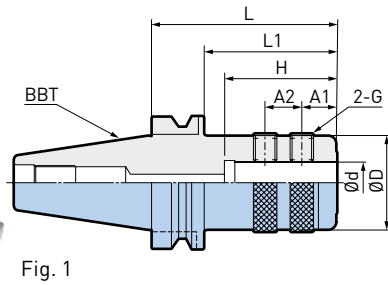

Fig. 1

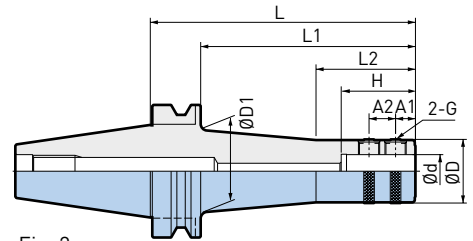

Fig. 2

Ø16 - 50mm

Modelo	Artículo No.	Fig.	Ød	ØD	ØD1	L	L1	L2	H	A1	A2	G	Peso (kg)
BBT30-TSL16-75	800.064	1	16	48	-	75	-	-	48	14	14	M10	1.00
BBT30-TSL20-75	978.314	1	20	48	-	75	-	-	50	14	14	M10	0.95
BBT30-TSL25-80	978.315	1	25	48	-	80	-	-	56	15	20	M16	0.93
BBT30-TSL32-85	805.243	1	32	63	-	85	-	-	60	15	20	M16	1.34
BBT40-TSL16-90	800.175	1	16	48	-	90	63	-	48	14	14	M10	1.70
BBT40-TSL16-105	800.174	1	16	48	-	105	78	-	48	14	14	M10	1.90
BBT40-TSL20-90	800.177	1	20	48	-	90	63	-	50	14	14	M10	1.70
BBT40-TSL20-105	800.176	1	20	48	-	105	78	-	50	14	14	M10	1.90
BBT40-TSL25-90	800.179	1	25	48	-	90	63	-	56	15	20	M16	1.60
BBT40-TSL25-105	800.178	1	25	48	-	105	78	-	56	15	20	M16	1.80
BBT40-TSL32-105	978.318	1	32	63	-	105	78	-	60	15	20	M16	2.40
BBT40-TSL32-135	800.180	1	32	63	-	135	108	-	60	15	20	M16	3.10
BBT40-TSL40-105	978.317	1	40	68	-	105	-	-	70	15	25	M16	2.40
BBT50-TSL16-90	800.369	1	16	48	-	90	52	-	48	14	14	M10	4.20
BBT50-TSL16-135	800.366	1	16	48	-	135	97	-	48	14	14	M10	4.80
BBT50-TSL16-165	800.367	1	16	48	-	165	127	-	48	14	14	M10	5.20
BBT50-TSL16-200	800.368	2	16	48	62.5	200	162	75	48	14	14	M10	6.00
BBT50-TSL20-90	800.374	1	20	48	-	90	52	-	50	14	14	M10	4.10
BBT50-TSL20-135	800.370	1	20	48	-	135	97	-	50	14	14	M10	4.70
BBT50-TSL20-165	800.371	1	20	48	-	165	127	-	50	14	14	M10	5.10
BBT50-TSL20-200	800.372	2	20	48	62.5	200	162	75	50	14	14	M10	5.90
BBT50-TSL20-250	800.373	2	20	48	64	250	212	90	50	14	14	M10	6.70
BBT50-TSL25-105	800.375	1	25	48	-	105	67	-	56	15	20	M16	4.20
BBT50-TSL25-135	800.376	1	25	48	-	135	97	-	56	15	20	M16	4.60
BBT50-TSL25-165	800.377	1	25	48	-	165	127	-	56	15	20	M16	5.00
BBT50-TSL25-200	800.378	2	25	48	62.5	200	162	75	56	15	20	M16	5.80
BBT50-TSL25-250	800.379	2	25	48	64	250	212	90	56	15	20	M16	6.70
BBT50-TSL32-105	800.380	1	32	63	-	105	67	-	60	15	20	M16	4.80
BBT50-TSL32-135	800.381	1	32	63	-	135	97	-	60	15	20	M16	6.10
BBT50-TSL32-165	800.382	1	32	63	-	165	127	-	60	15	20	M16	6.20
BBT50-TSL32-200	800.383	1	32	63	-	200	162	-	60	15	20	M16	6.90
BBT50-TSL32-250	800.384	1	32	63	-	250	212	-	60	15	20	M16	8.00
BBT50-TSL40-105	800.385	1	40	68	-	105	67	-	70	15	25	M16	4.70
BBT50-TSL40-135	800.386	1	40	68	-	135	97	-	70	15	25	M16	5.50
BBT50-TSL40-165	800.387	1	40	68	-	165	127	-	70	15	25	M16	6.30
BBT50-TSL40-200	800.388	1	40	68	-	200	162	-	70	15	25	M16	7.20
BBT50-TSL40-250	800.389	1	40	68	-	250	212	-	70	15	25	M16	8.50
BBT50-TSL50-105	800.390	1	50	84	-	105	67	-	70	15	25	M16	5.30
BBT50-TSL50-150	800.391	1	50	84	-	150	112	-	70	15	25	M16	7.20

## Accesorios & Recambios

Casquillos reductores



► 373

1. Pueden utilizarse portaherramientas BIG-PLUS® en centros de mecanizado con husillos DV convencionales.
2. «H» es la longitud máxima del mango de la herramienta que puede introducirse en estos modelos.
3. No compatible con Weldon DIN 1835B.

### Side Lock para Weldon

Para herramientas de corte según DIN 1835 forma B.

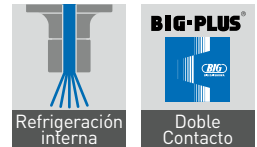

A.1

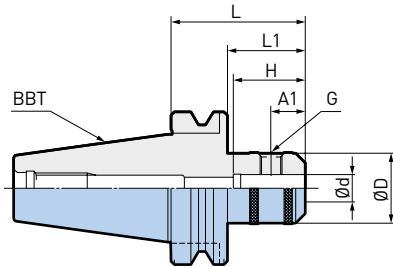

Fig. 1

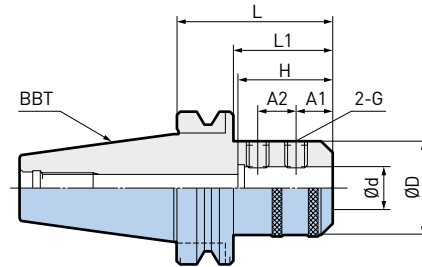

Fig. 2

ø6 - 50mm

Modelo	Artículo No.	Fig.	Ød	ØD	L	L1	A1	A2	H	G	Peso (kg)
BBT30-ISL6-60	961.394	1	6	25	60	38	18	-	85 *	M6	0.50
BBT30-ISL8-60	961.395	1	8	28	60	38	18	-	85 *	M8	0.52
BBT30-ISL10-60	961.396	1	10	35	60	38	20	-	45	M10	0.61
BBT30-ISL12-60	961.397	1	12	42	60	38	22.5	-	48	M12	0.71
BBT30-ISL16-60	966.341	1	16	48	60	38	24	-	53	M14	0.78
BBT40-ISL6-75	807.200	1	6	25	75	48	18	-	110 *	M6	1.20
BBT40-ISL8-75	807.201	1	8	28	75	48	18	-	110 *	M8	1.20
BBT40-ISL10-75	807.202	1	10	35	75	48	20	-	110 *	M10	1.30
BBT40-ISL12-75	961.362	1	12	42	75	48	22.5	-	110 *	M12	1.40
BBT40-ISL16-75	961.363	1	16	48	75	48	24	-	53	M14	1.50
BBT40-ISL20-75	961.364	1	20	52	75	48	25	-	55	M16	1.60
BBT40-ISL25-90	961.365	2	25	63.5	90	63	24	25	60	M18 P2	2.20
BBT40-ISL32-105	961.366	2	32	72	105	-	24	28	82	M20 P2	2.80
BBT50-ISL16-90	961.367	1	16	48	90	52	24	-	145 *	M14	4.10
BBT50-ISL16-150	800.297	2	16	48	150	60	24	-	205 *	M14	5.00
BBT50-ISL20-90	961.368	1	20	52	90	52	25	-	145 *	M16	4.20
BBT50-ISL20-150	800.299	2	20	52	150	60	25	-	60	M16	5.20
BBT50-ISL25-105	961.369	2	25	65	105	67	24	25	60	M18 P2	4.90
BBT50-ISL25-150	800.301	2	25	65	150	107	24	25	60	M18 P2	6.00
BBT50-ISL32-105	978.017	2	32	72	105	67	24	28	90	M20 P2	5.10
BBT50-ISL32-150	800.303	2	32	72	150	107	24	28	90	M20 P2	6.30
BBT50-ISL40-120	978.018	2	40	90	120	82	30	32	90	M20 P2	6.50
BBT50-ISL40-150	800.305	2	40	90	150	109	30	32	90	M20 P2	8.00
BBT50-ISL42-120	800.307	2	42	90	120	79	30	32	90	M20 P2	6.50
BBT50-ISL42-150	800.308	2	42	99,5	150	109	30	32	90	M20 P2	7.90
BBT50-ISL50-121	978.294	2	50	99.5	121	83	35	35	90	M24 P2	7.00

1. Pueden utilizarse portaherramientas BIG-PLUS® en centros de mecanizado con husillos DV convencionales.
2. Use herramientas de acuerdo a la norma DIN 1835 B/DIN 6535 HB y ISO 5414.
3. «H» es la longitud máxima del mango de la herramienta que puede introducirse en estos modelos.
4. Dimensión H marcada con \* indica la distancia al tornillo de retención.

## Side Lock para Weldon

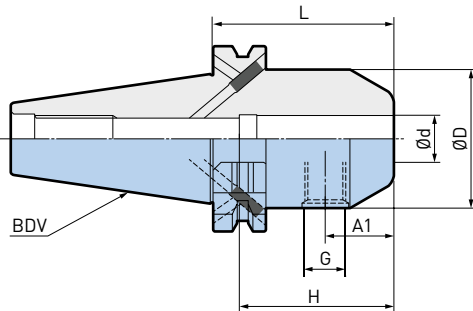
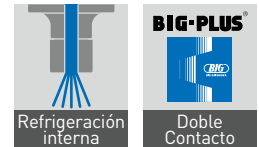

Fig. 1

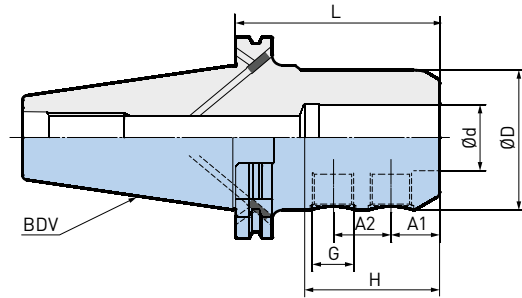

Fig. 2

ø6 - 40mm

Modelo	Artículo No.	Fig.	Ød	ØD	L	A1	A2	H	G	Peso (kg)
BDV40-ISL6-50	490.106	1	6	25	50	17.5	-	85 *	M6	0.90
BDV40-ISL8-50	490.108	1	8	28	50	17.5	-	85 *	M8	0.90
BDV40-ISL10-50	490.110	1	10	35	50	19.5	-	85 *	M10	1.00
BDV40-ISL12-50	490.112	1	12	42	50	22	-	85 *	M12	1.10
BDV40-ISL16-63	490.116	1	16	48	63	23.5	-	53	M14	1.30
BDV40-ISL20-63	490.120	1	20	52	63	24.5	-	55	M16	1.40
BDV40-ISL25-100	490.125	2	25	65	100	23.5	25	60	M18 P2	2.50
BDV40-ISL32-100	490.132	2	32	72	100	23.5	28	66	M20 P2	2.60
BDV50-ISL6-63	490.206	1	6	25	63	17.5	-	116 *	M6	2.70
BDV50-ISL8-63	490.208	1	8	28	63	17.5	-	116 *	M8	2.80
BDV50-ISL10-63	490.210	1	10	35	63	19.5	-	116 *	M10	2.90
BDV50-ISL12-63	490.212	1	12	42	63	22	-	116 *	M12	3.00
BDV50-ISL16-63	490.216	1	16	48	63	23.5	-	116 *	M14	3.10
BDV50-ISL20-63	490.220	1	20	52	63	24.5	-	116 *	M16	3.20
BDV50-ISL25-80	490.225	2	25	65	80	23.5	25	60	M18 P2	3.90
BDV50-ISL32-100	490.232	2	32	70	100	23.5	28	66	M20 P2	4.50
BDV50-ISL40-100	490.240	2	40	90	100	29.5	32	79	M20 P2	5.50

1. Pueden utilizarse portaherramientas BIG-PLUS® en centros de mecanizado con husillos DV convencionales.
2. «H» es la longitud máxima del mango de la herramienta que puede introducirse en estos modelos.
3. Use herramientas de acuerdo a las normas DIN 1835 B / DIN 6538 HB.
4. Dimensión H marcada con \* indica la distancia al tornillo de retención.

## Portapuntas Super Keyless

Portabrocas de cambio rápido.

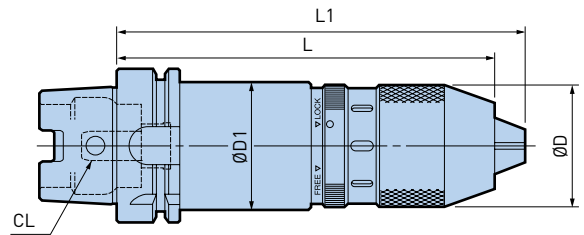

A.3

Ø0.5 - 13mm

Modelo	Artículo No.	Ød	ØD	ØD1	L	L1	Llave	Peso (kg)
HSK-A63-SKL13-155	805.282	0.5 - 13	51	53	155	167.5	FS13LC	2.36

1. No dispone de agujero de refrigeración interior.
2. Se incluye la llave.

## Side Lock Drill Holder

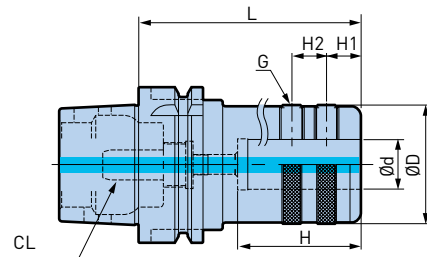

Ø16 - 50mm

Modelo	Artículo No.	Ød	ØD	L	H	H1	H2	G	Peso (kg)
HSK-A63-TSL16-90	805.234	16	48	90	48	14	14	M10	1.50
HSK-A63-TSL20-90	805.235	20	48	90	50	14	14	M10	1.40
HSK-A63-TSL25-90	805.236	25	48	90	56	15	20	M16	1.40
HSK-A63-TSL32-105	805.237	32	63	105	60	15	20	M16	2.00
HSK-A63-TSL40-120	805.232	40	68	120	70	15	25	M16	2.40
HSK-A100-TSL16-90	806.044	16	48	90	48	14	14	M10	2.90
HSK-A100-TSL20-90	806.045	20	48	90	50	14	14	M10	2.90
HSK-A100-TSL25-90	806.046	25	48	90	56	15	20	M16	2.80
HSK-A100-TSL32-105	806.047	32	63	105	60	15	20	M16	3.50
HSK-A100-TSL40-105	806.048	40	68	105	70	15	25	M16	3.60
HSK-A100-TSL50-105	806.049	50	84	105	70	15	25	M16	4.20

1. El tubo para refrigerante (CL) hay que pedirlo por separado.

### Accesorios & Recambios

Casquillos reductores



► 373

## Side Lock para Weldon

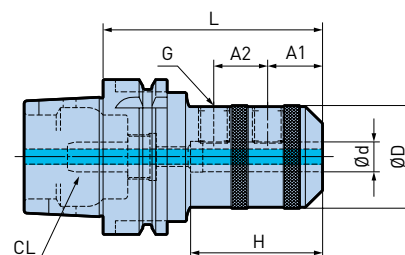

A.3

ø6 - 50mm

Modelo	Artículo No.	Ød	ØD	L	A1	A2	H	G	Peso (kg)
HSK-A63-ISL6-80	807.321	6	25	80	18	-	58	M6	0.90
HSK-A63-ISL8-80	807.322	8	28	80	18	-	58	M8	1.00
HSK-A63-ISL10-80	807.323	10	35	80	20	-	44	M10	1.10
HSK-A63-ISL12-80	805.732	12	42	80	22.5	-	50	M12	1.20
HSK-A63-ISL16-80	807.319	16	48	80	24	-	52	M14	1.40
HSK-A63-ISL20-80	806.050	20	52	80	25	-	54	M16	1.40
HSK-A63-ISL25-105	805.019	25	65	105	24	25	60	M18 P2	2.20
HSK-A63-ISL32-115	805.018	32	72	115	24	28	64	M20 P2	2.70
HSK-A100-ISL20-90	805.152	20	52	90	25	-	54	M16	3.00
HSK-A100-ISL20-135	807.227	20	52	135	25	-	55	M16	3.60
HSK-A100-ISL20-195	-	20	52	195	25	-	54	M16	4.60
HSK-A100-ISL25-105	806.051	25	65	105	24	25	60	M18 P2	3.70
HSK-A100-ISL25-135	807.228	25	65	135	24	25	60	M18 P2	4.40
HSK-A100-ISL25-195	-	25	65	195	24	25	60	M18	5.90
HSK-A100-ISL32-125	805.151	32	72	125	24	28	90	M20 P2	4.50
HSK-A100-ISL32-165	807.229	32	72	165	24	28	90	M20 P2	5.70
HSK-A100-ISL32-195	-	32	72	195	24	28	90	M20	6.60
HSK-A100-ISL40-125	805.201	40	90	125	30	32	90	M20 P2	5.60
HSK-A100-ISL40-165	807.230	40	90	165	30	32	90	M20 P2	7.50
HSK-A100-ISL40-210	-	40	90	210	30	32	90	M20	9.80
HSK-A100-ISL50-135	806.052	50	99.5	135	35	35	90	M24 P2	6.70
HSK-A100-ISL50-165	807.231	50	99.5	165	35	35	90	M24 P2	8.30
HSK-A100-ISL50-210	-	50	99.5	210	35	35	90	M24	11.00

1. «H» es la longitud máxima del mango de la herramienta que puede introducirse en estos modelos.
2. Use herramientas de acuerdo a la norma DIN 1835 B/DIN 6535 HB y ISO 5414.
3. El tubo para refrigerante (CL) hay que pedirlo por separado.

### Accesorios & Recambios

Tubos para refrigerante Tipo A/E



► 250

## Side Lock para Brocas

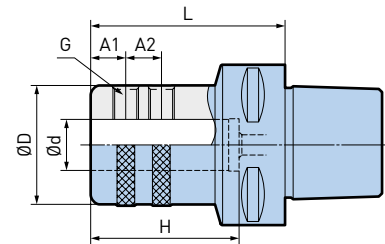

A.4

ø16 - 40mm

Modelo	Artículo No.	Ød	ØD	L	A1	A2	H	G	Peso (kg)
C4-TSL16-56	800.687	16	48	56	14	14	48	M10 P1.25	0.65
C4-TSL20-60	800.688	20	48	60	14	14	50	M10 P1.25	0.66
C4-TSL25-77	800.689	25	48	77	15	20	56	M16 P1.5	0.79
C5-TSL16-60	973.115	16	48	60	14	14	48	M10 P1.25	0.90
C5-TSL20-60	973.116	20	48	60	14	14	50	M10 P1.25	0.90
C5-TSL25-75	973.117	25	48	75	15	20	56	M16 P1.5	1.00
C5-TSL32-85	800.775	32	63	85	15	20	60	M16 P1.5	1.50
C6-TSL16-70	973.119	16	48	70	14	14	48	M10 P1.25	1.30
C6-TSL20-70	973.120	20	48	70	14	14	50	M10 P1.25	1.30
C6-TSL25-70	973.121	25	48	70	15	20	56	M16 P1.5	1.20
C6-TSL32-75	973.122	32	63	75	15	20	60	M16 P1.5	1.60
C6-TSL40-85	973.123	40	68	85	15	25	70	M16 P1.5	1.80
C8-TSL16-80	973.124	16	48	80	14	14	48	M10 P1.25	2.40
C8-TSL20-80	973.125	20	48	80	14	14	50	M10 P1.25	2.30
C8-TSL25-85	973.126	25	48	85	15	20	56	M16 P1.5	2.30
C8-TSL32-90	973.127	32	63	90	15	20	60	M16 P1.5	2.70
C8-TSL40-95	973.128	40	68	95	15	25	70	M16 P1.5	2.80

1. «H» es la longitud máxima del mango de la herramienta que puede introducirse en estos modelos.
2. No compatible con Weldon DIN 1835B.

## Accesorios &amp; Recambios

Casquillos reductores



► 373

## Side lock para Weldon

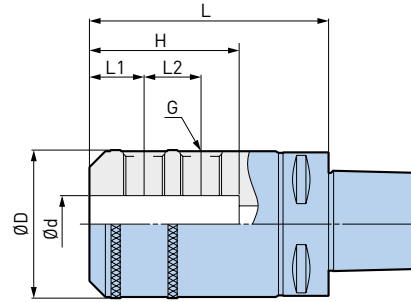

ø16 - 32mm

A.4

Modelo	Artículo No.	Ød	ØD	L	L1	L2	H	G	Peso (kg)
C6-ISL16-80	973.562	16	48	80	24	-	52	M14	1.40
C6-ISL20-80	973.563	20	52	80	25	-	55	M16	1.50
C6-ISL25-105	973.564	25	65	105	24	25	60	M18 P2.0	2.90
C6-ISL32-115	973.565	32	72	115	24	28	90	M20 P2.0	3.00

- «H» es la longitud máxima del mango de la herramienta que puede introducirse en estos modelos.
- Use herramientas de acuerdo a la norma DIN 1835 B/DIN 6535 HB y ISO 5414.
- \* El suministro de refrigerante periférico no está disponible.