

## Contents:

Page:

## Contents:

Page:

Carbide Shank Turning Toolholder	2
Boring bar, SWUBR/L type Lead angle $k=3^\circ$ and Inserts	2
Boring bar, SCLCR/L type Lead angle $k=5^\circ$	3

Boring bar, SDUCR/L type Lead angle $k=3^\circ$	4
Boring bar, STFPR/L type Lead angle $k=1^\circ$	5

## Carbide Shank Turning Toolholder

High performance Carbide Shank turning toolholders for internal machining from 6 mm (.236") minimum diameter and larger.

- Unique Carbide type for high rigidity
- Cylindrical shank
- Internal coolant supply to the cutting edge
- Screw clamping design

### Boring bar, SWUBR/L type Lead angle $k=3^\circ$ and Inserts

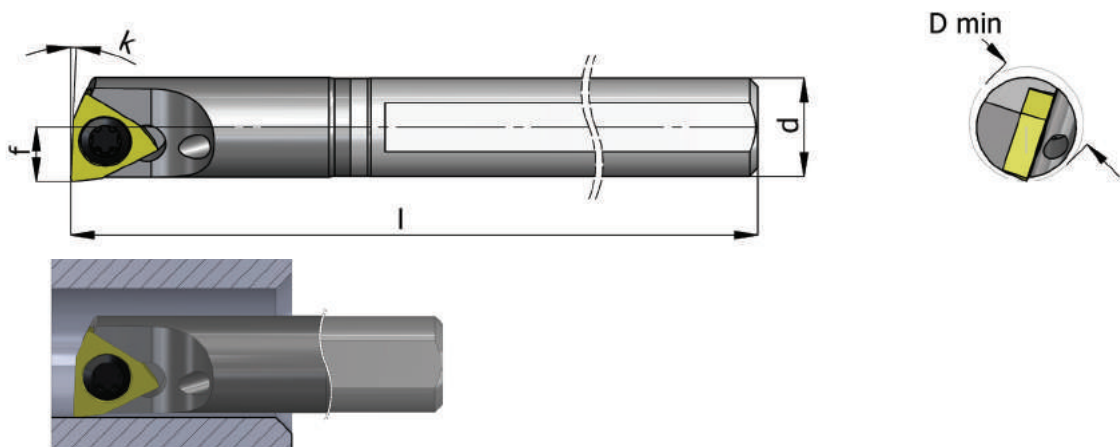

Ordering Code	R. Hand L. Hand	d	Min Bore Dia	l	f	k	Insert Screw	Torx Key	Insert
<b>E06H SWUBR-06</b> *(SIR 0006 H06CT)	R	6	6.5	100	3.2	3°	S06	K06	WBMT 06 01 02L *(06 IR TURN BMA)
<b>E06H SWUBL-06</b>	L	6	6.5	100	3.2	3°	S06	K06	WBMT 06 01 02R *(06 IL TURN BMA)
<b>E08K SWUBR-06</b> *(SIR 0008 K06CT)	R	8	8.6	125	4.2	3°	S06	K06	WBMT 06 01 02L *(06 IR TURN BMA)
<b>E08K SWUBL-06</b>	L	8	8.6	125	4.2	3°	S06	K06	WBMT 06 01 02R *(06 IL TURN BMA)
<b>E10M SWUBR-06</b> *(SIR 0010 M06CT)	R	10	11.0	150	5.5	3°	S06	K06	WBMT 06 01 02L *(06 IR TURN BMA)
<b>E10M SWUBL-06</b>	L	10	11.0	150	5.5	3°	S06	K06	WBMT 06 01 02R *(06 IL TURN BMA)

\*Old item description

## Boring bar, SLCR/L type Lead angle $k=5^\circ$

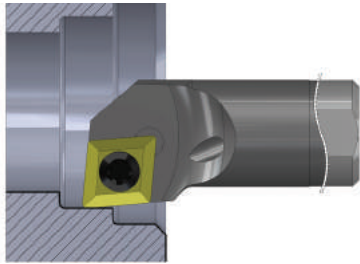
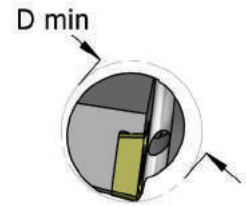
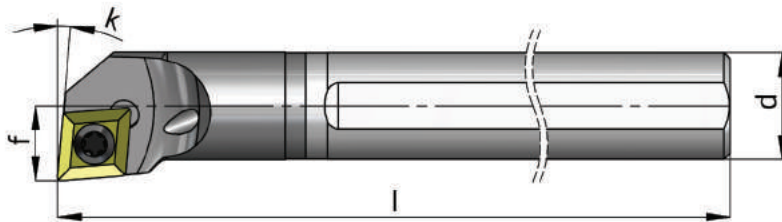

Ordering Code	R. Hand L. Hand	d	Min Bore Dia	l	f	k	Insert Screw	Torx Key	Insert*
<b>E08K SLCR-06</b>	R	8	10.0	125	4.9	5°	S09	K07	CCMT 06 02 04
<b>E08K SCLCL-06</b>	L	8	10.0	125	4.9	5°	S09	K07	CCMT 06 02 04
<b>E10M SLCR-06</b>	R	10	14.0	150	6.9	5°	S09	K07	CCMT 06 02 04
<b>E10M SCLCL-06</b>	L	10	14.0	150	6.9	5°	S09	K07	CCMT 06 02 04
<b>E12P SLCR-06</b>	R	12	16.0	170	8.9	5°	S09	K07	CCMT 06 02 04
<b>E12P SCLCL-06</b>	L	12	16.0	170	8.9	5°	S09	K07	CCMT 06 02 04
<b>E16R SLCR-06</b>	R	16	20.0	200	10.9	5°	S09	K07	CCMT 06 02 04
<b>E16R SCLCL-06</b>	L	16	20.0	200	10.9	5°	S09	K07	CCMT 06 02 04
<b>E16R SLCR-09</b>	R	16	20.0	200	10.9	5°	S20	K22	CCMT 09 T3 08
<b>E16R SCLCL-09</b>	L	16	20.0	200	10.9	5°	S20	K22	CCMT 09 T3 08

\*Carmex doesn't offer the inserts

## Boring bar, SDUCR/L type Lead angle $k=3^\circ$

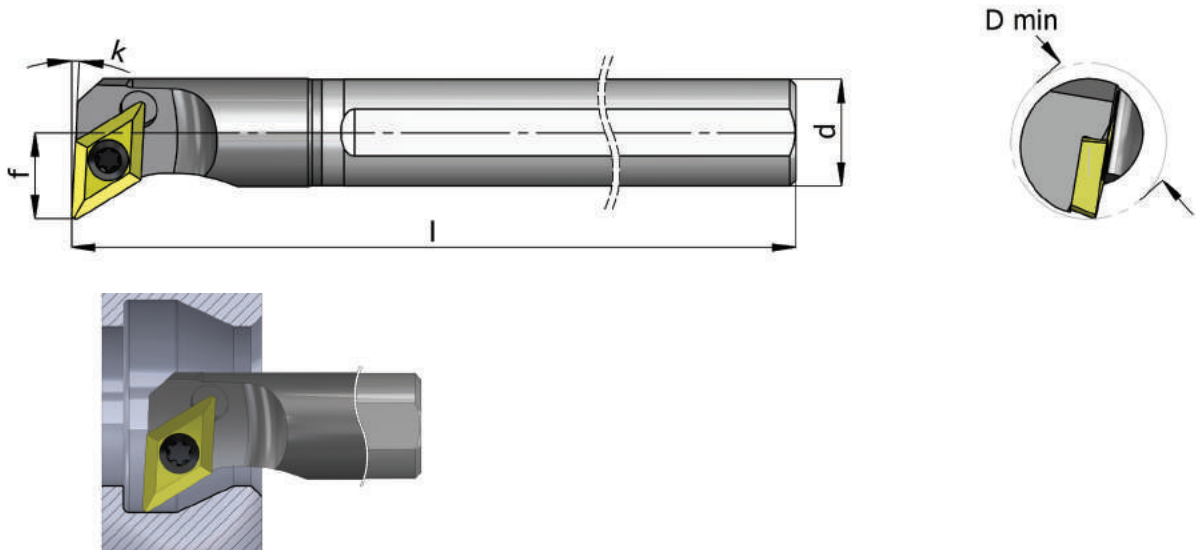

Ordering Code	R. Hand L. Hand	d	Min Bore Dia	l	f	k	Insert Screw	Torx Key	Insert*
<b>E10M SDUCR-07</b>	R	10	14.0	150	7.9	3°	S09	K07	DCMT 07 02 04
<b>E10M SDUCL-07</b>	L	10	14.0	150	7.9	3°	S09	K07	DCMT 07 02 04
<b>E12P SDUCR-07</b>	R	12	16.0	170	8.9	3°	S09	K07	DCMT 07 02 04
<b>E12P SDUCL-07</b>	L	12	16.0	170	8.9	3°	S09	K07	DCMT 07 02 04
<b>E16R SDUCR-07</b>	R	16	20.0	200	10.9	3°	S09	K07	DCMT 07 02 04
<b>E16R SDUCL-07</b>	L	16	20.0	200	10.9	3°	S09	K07	DCMT 07 02 04

\*Carmex doesn't offer the inserts

## Boring bar, *STFPR/L type* Lead angle $k=1^\circ$

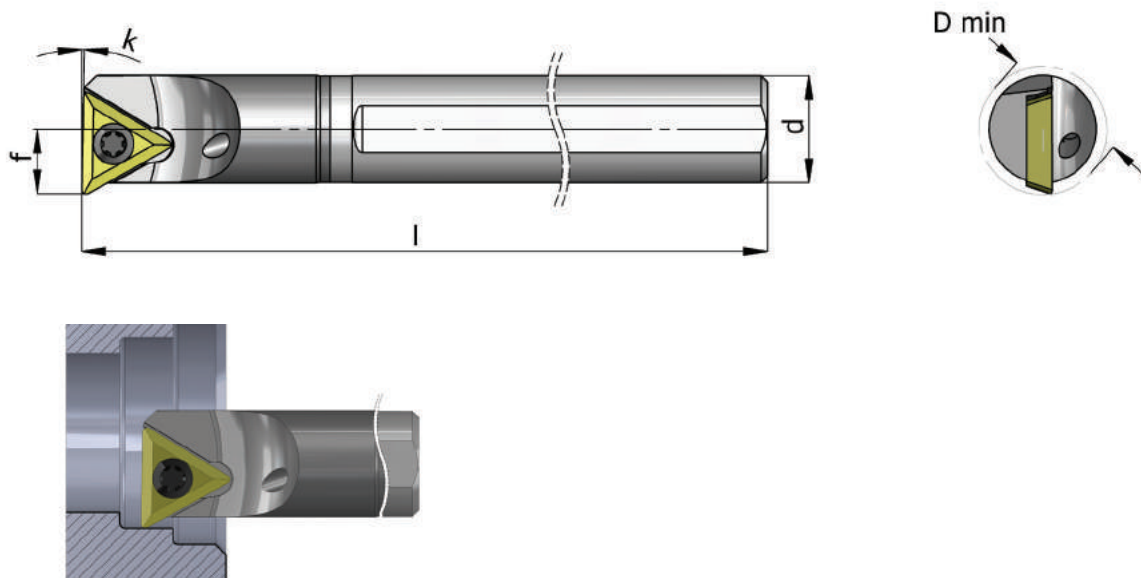

Ordering Code	R. Hand L. Hand	d	Min Bore Dia	l	f	k	Insert Screw	Torx Key	Insert*
<b>E10M STFPR-11</b>	R	10	11.0	150	5.9	1°	S18	K07	TPGB 11 03 04
<b>E10M STFPL-11</b>	L	10	11.0	150	5.9	1°	S18	K07	TPGB 11 03 04
<b>E12P STFPR-11</b>	R	12	14.0	170	6.9	1°	S18	K07	TPGB 11 03 04
<b>E12P STFPL-11</b>	L	12	14.0	170	6.9	1°	S18	K07	TPGB 11 03 04

\*Carmex doesn't offer the inserts

