

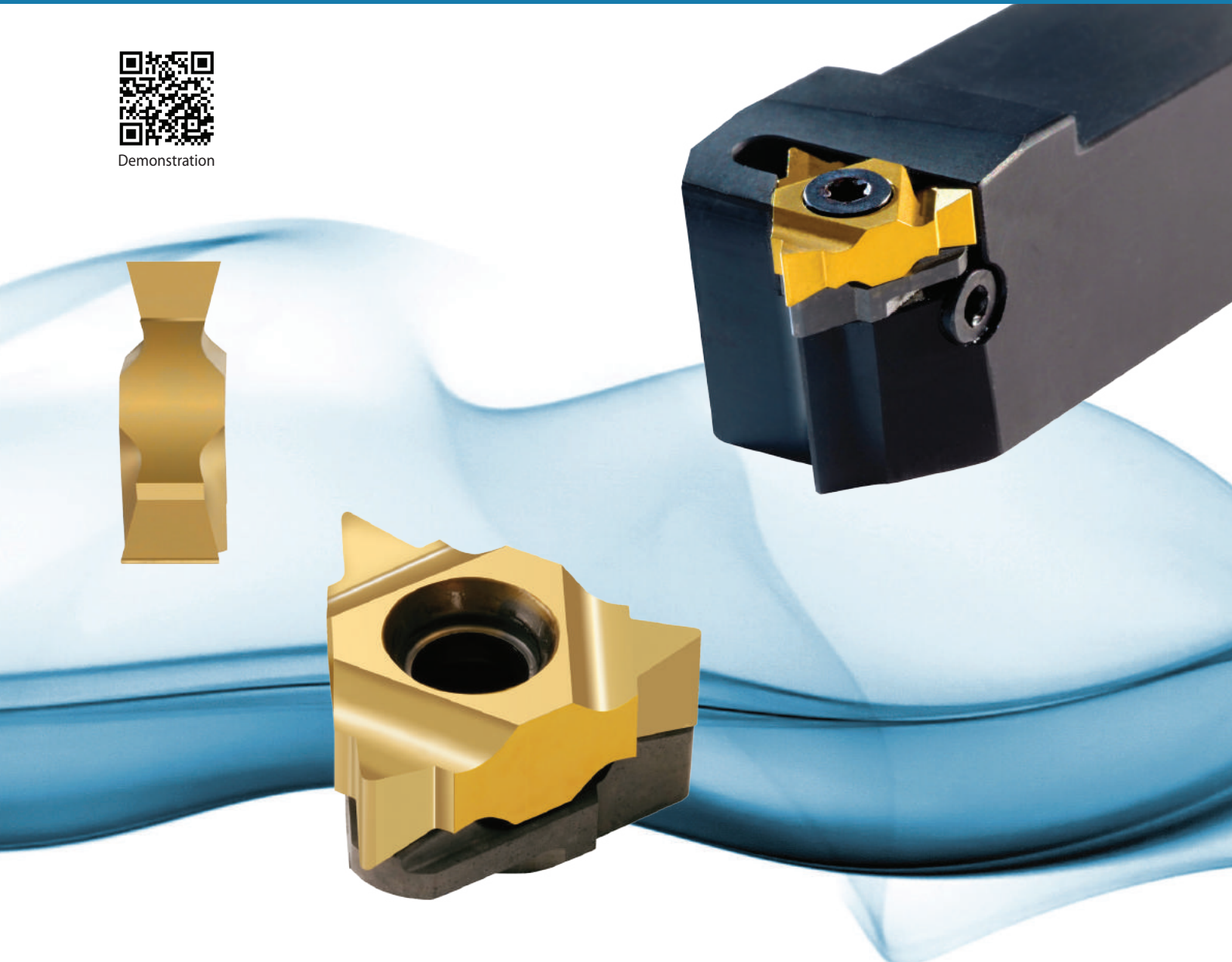

Demonstration



**A unique line of 2 sided inserts including 6 cutting edges, a cost saving tool.**

## Advantages of DSI-Thread Turning Inserts

- Increased productivity thanks to the six cutting edges.
- U-Style inserts for a wide range of full or partial profile standard threads.
- Same insert for right hand or left hand thread.
- Saving on tooling costs.
- Unique anti-vibration anvil designed for clamping the insert and supporting the cutting edge.
- Simple insert's mounting and cutting edge indexing.
- Heavy duty toolholders designed specially for this line.

### Contents:

### Page:

Product Identification	2
Partial Profile 60°	3
Partial Profile 55°	3
ISO	4
UN	4

### Contents:

### Page:

Whitworth 55°	5
NPT	5
Heavy Duty Thread Turning Toolholders - External	6
Heavy Duty Thread Turning Toolholders - Internal	6

## Product Identification

### DSI Ordering Code

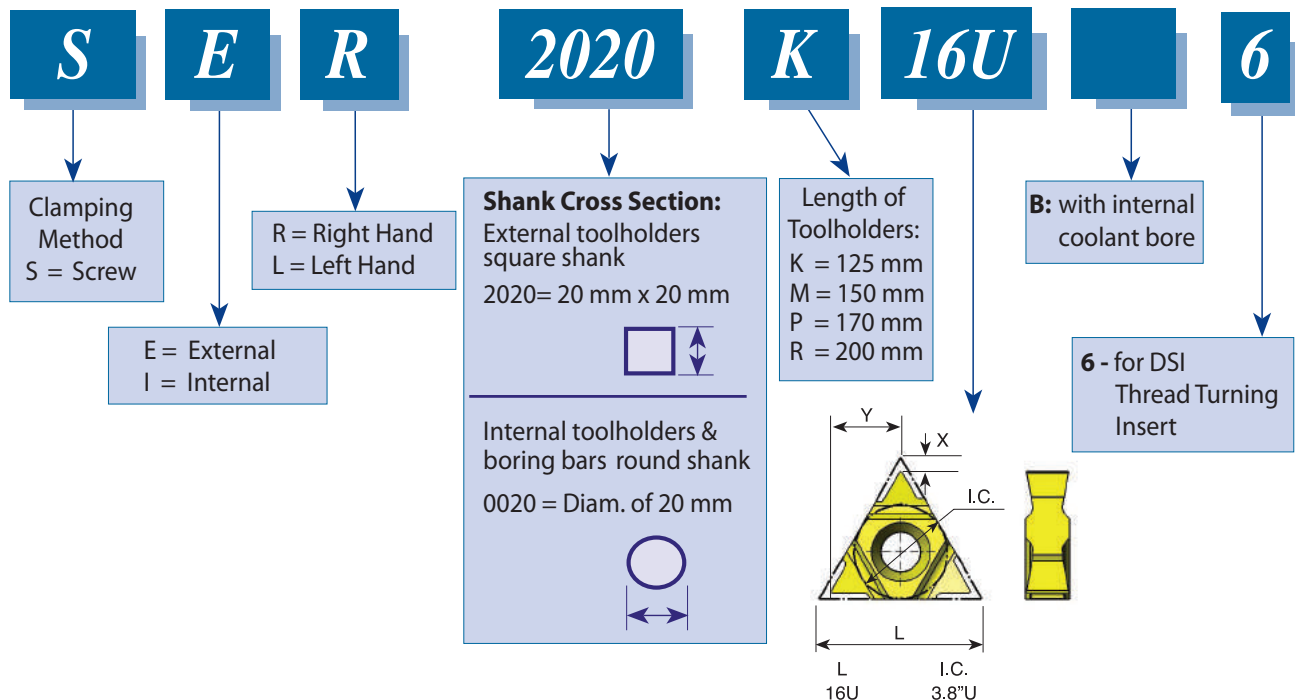
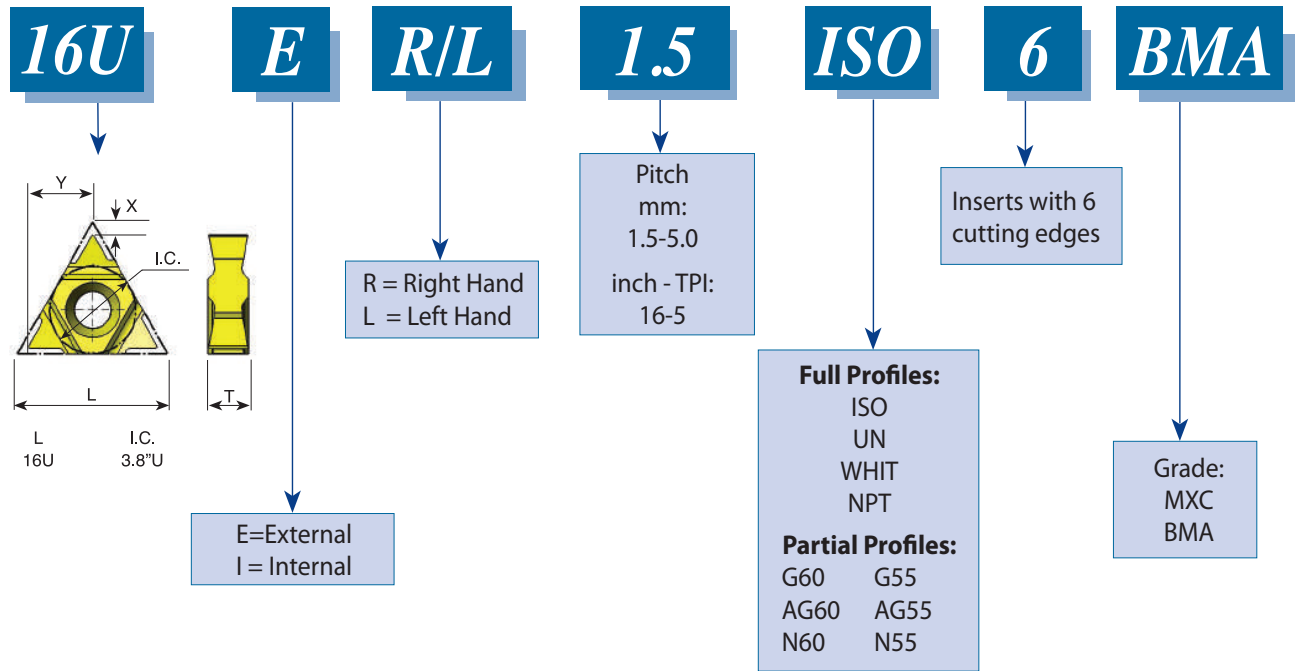

## Partial Profile 60°

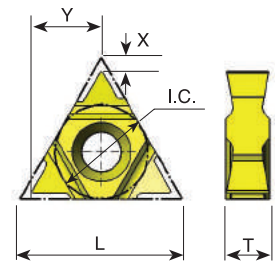

Pitch Range mm	Pitch Range TPI	L	I.C. in	<b>EXTERNAL</b> Ordering Code	<b>INTERNAL</b> Ordering Code	X	Y	T
1.75 - 3.0	14-8	16U	3/8U	<b>16U ER/L G60-6</b>	<b>16U IR/L G60-6</b>	1.4	7.1	4.5
0.5 - 3.0	48-8	16U	3/8U	<b>16U ER/L AG60-6</b>	<b>16U IR/L AG60-6</b>	1.4	7.1	4.5
3.5 - 5.0	7-5	16U	3/8U	<b>16U ER/L N60-6</b>	<b>16U IR/L N60-6</b>	1.2	7.3	4.5

Available grades: BMA or MXC

Order example: 16U ER/L G60-6 BMA

## Partial Profile 55°

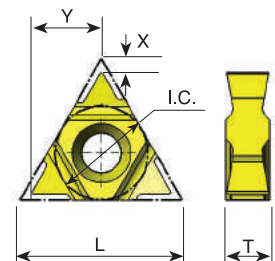

Pitch Range mm	Pitch Range TPI	L	I.C. in	<b>EXTERNAL</b> Ordering Code	<b>INTERNAL</b> Ordering Code	X	Y	T
1.75 - 3.0	14-8	16U	3/8U	<b>16U ER/L G55-6</b>	<b>16U IR/L G55-6</b>	1.4	7.1	4.5
0.5 - 3.0	48-8	16U	3/8U	<b>16U ER/L AG55-6</b>	<b>16U IR/L AG55-6</b>	1.4	7.1	4.5
3.5 - 5.0	7-5	16U	3/8U	<b>16U ER/L N55-6</b>	<b>16U IR/L N55-6</b>	1.2	7.3	4.5

Available grades: BMA or MXC

## ISO

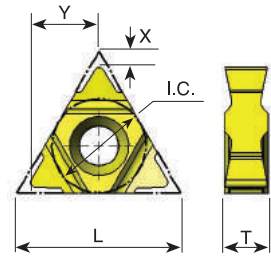

Pitch mm	L	I.C. in	<b>EXTERNAL</b> Ordering Code	<b>INTERNAL</b> Ordering Code	X	Y	T
1.5	16U	3/8U	<b>16U ER/L 1.5 ISO-6</b>	<b>16U IR/L 1.5 ISO-6</b>	1.6	6.9	4.5
1.75	16U	3/8U	<b>16U ER/L 1.75 ISO-6</b>	<b>16U IR/L 1.75 ISO-6</b>	1.6	6.9	4.5
2.0	16U	3/8U	<b>16U ER/L 2.0 ISO-6</b>	<b>16U IR/L 2.0 ISO-6</b>	1.6	6.9	4.5
2.5	16U	3/8U	<b>16U ER/L 2.5 ISO-6</b>	<b>16U IR/L 2.5 ISO-6</b>	1.6	6.9	4.5
3.0	16U	3/8U	<b>16U ER/L 3.0 ISO-6</b>	<b>16U IR/L 3.0 ISO-6</b>	1.6	6.9	4.5
3.5	16U	3/8U	<b>16U ER/L 3.5 ISO-6</b>	<b>16U IR/L 3.5 ISO-6</b>	1.6	6.9	4.5
4.0	16U	3/8U	<b>16U ER/L 4.0 ISO-6</b>	<b>16U IR/L 4.0 ISO-6</b>	1.6	6.9	4.5
4.5	16U	3/8U	<b>16U ER/L 4.5 ISO-6</b>	<b>16U IR/L 4.5 ISO-6</b>	1.6	6.9	4.5
5.0	16U	3/8U	<b>16U ER/L 5.0 ISO-6</b>	<b>16U IR/L 5.0 ISO-6</b>	1.6	6.9	4.5

Available grades: BMA or MXC

Order example: 16U ER/L 1.75 ISO-6 BMA

## UN - Unified **UNC, UNF, UNEF, UNS**

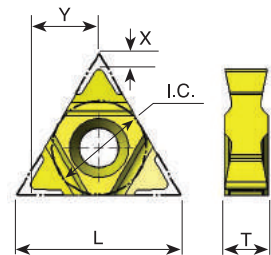

Pitch TPI	L	I.C. in	<b>EXTERNAL</b> Ordering Code	<b>INTERNAL</b> Ordering Code	X	Y	T
16	16U	3/8U	<b>16U ER/L 16 UN-6</b>	<b>16U IR/L 16 UN-6</b>	1.6	6.9	4.5
14	16U	3/8U	<b>16U ER/L 14 UN-6</b>	<b>16U IR/L 14 UN-6</b>	1.6	6.9	4.5
13	16U	3/8U	<b>16U ER/L 13 UN-6</b>	<b>16U IR/L 13 UN-6</b>	1.6	6.9	4.5
12	16U	3/8U	<b>16U ER/L 12 UN-6</b>	<b>16U IR/L 12 UN-6</b>	1.6	6.9	4.5
11.5	16U	3/8U	<b>16U ER/L 11.5 UN-6</b>	<b>16U IR/L 11.5 UN-6</b>	1.6	6.9	4.5
11	16U	3/8U	<b>16U ER/L 11 UN-6</b>	<b>16U IR/L 11 UN-6</b>	1.6	6.9	4.5
10	16U	3/8U	<b>16U ER/L 10 UN-6</b>	<b>16U IR/L 10 UN-6</b>	1.6	6.9	4.5
9	16U	3/8U	<b>16U ER/L 9 UN-6</b>	<b>16U IR/L 9 UN-6</b>	1.6	6.9	4.5
8	16U	3/8U	<b>16U ER/L 8 UN-6</b>	<b>16U IR/L 8 UN-6</b>	1.6	6.9	4.5
7	16U	3/8U	<b>16U ER/L 7 UN-6</b>	<b>16U IR/L 7 UN-6</b>	1.6	6.9	4.5
6	16U	3/8U	<b>16U ER/L 6 UN-6</b>	<b>16U IR/L 6 UN-6</b>	1.6	6.9	4.5
5	16U	3/8U	<b>16U ER/L 5 UN-6</b>	<b>16U IR/L 5 UN-6</b>	1.6	6.9	4.5

Available grades: BMA or MXC

For carbide grade and cutting speed see page A04-2 and 3

## Whitworth 55° BSW, BSF, BSP, BSB

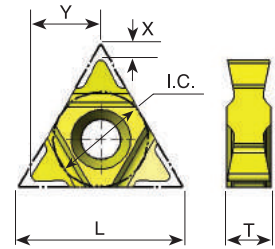

Pitch TPI	L	I.C. in	<b>EXTERNAL</b> Ordering Code	<b>INTERNAL</b> Ordering Code	X	Y	T
16	16U	3/8U	<b>16U ER/L 16 W-6</b>	<b>16U IR/L 16 W-6</b>	1.6	6.9	4.5
14	16U	3/8U	<b>16U ER/L 14 W-6</b>	<b>16U IR/L 14 W-6</b>	1.6	6.9	4.5
12	16U	3/8U	<b>16U ER/L 12 W-6</b>	<b>16U IR/L 12 W-6</b>	1.6	6.9	4.5
11	16U	3/8U	<b>16U ER/L 11 W-6</b>	<b>16U IR/L 11 W-6</b>	1.6	6.9	4.5
10	16U	3/8U	<b>16U ER/L 10 W-6</b>	<b>16U IR/L 10 W-6</b>	1.6	6.9	4.5
9	16U	3/8U	<b>16U ER/L 9 W-6</b>	<b>16U IR/L 9 W-6</b>	1.6	6.9	4.5
8	16U	3/8U	<b>16U ER/L 8 W-6</b>	<b>16U IR/L 8 W-6</b>	1.6	6.9	4.5
7	16U	3/8U	<b>16U ER/L 7 W-6</b>	<b>16U IR/L 7 W-6</b>	1.6	6.9	4.5
6	16U	3/8U	<b>16U ER/L 6 W-6</b>	<b>16U IR/L 6 W-6</b>	1.6	6.9	4.5
5	16U	3/8U	<b>16U ER/L 5 W-6</b>	<b>16U IR/L 5 W-6</b>	1.4	7.2	4.5

Available grades: BMA or MXC  
Order example: 16U ER/L 9 W-6 BMA

## NPT

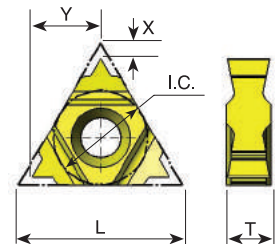

Pitch TPI	L	I.C. in	<b>EXTERNAL</b> Ordering Code	<b>INTERNAL</b> Ordering Code	X	Y	T
14	16U	3/8U	<b>16U ER/L 14 NPT-6</b>	<b>16U IR/L 14 NPT-6</b>	1.6	6.9	4.5
11.5	16U	3/8U	<b>16U ER/L 11.5 NPT-6</b>	<b>16U IR/L 11.5 NPT-6</b>	1.6	6.9	4.5
8	16U	3/8U	<b>16U ER/L 8 NPT-6</b>	<b>16U IR/L 8 NPT-6</b>	1.6	6.9	4.5

Available grades: BMA or MXC

## Heavy Duty Thread Turning Toolholders

### External

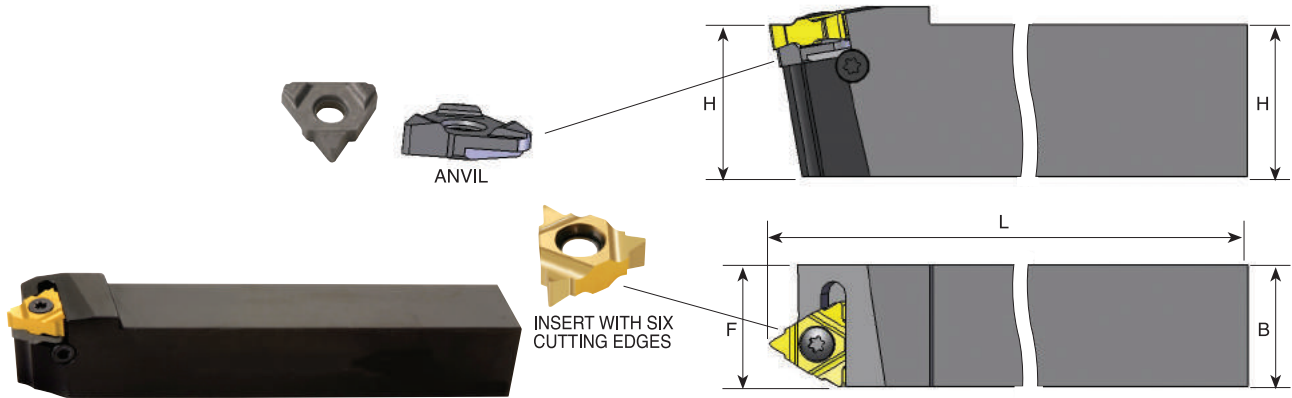

Ordering Code Right Hand	H	B	L	F	Insert Screw	Anvil Screw	Torx Key	RH Anvil	LH Anvil
<b>SER 2020 K16U-6</b>	20	20	125	20	S16	A16	K16	AER 16U-6	AEL 16U-6
<b>SER 2520 M16U-6</b>	25	20	150	20	S16	A16	K16	AER 16U-6	AEL 16U-6

For **LEFT HAND** toolholders specify **SEL** instead of **SER**

### Internal with coolant bore

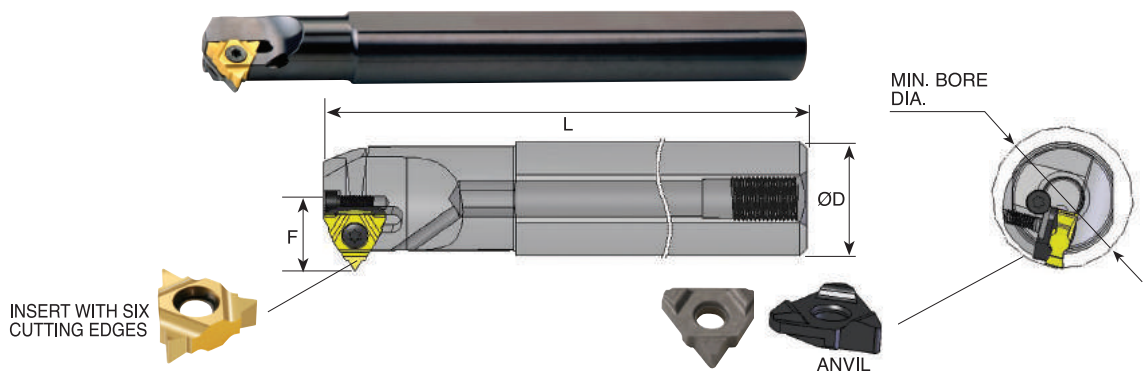

Ordering Code Right Hand	ØD	Min. bore dia.	L	F	Insert Screw	Anvil Screw	Torx Key	RH Anvil	LH Anvil
<b>SIR 0020 P16UB-6</b>	20	24	170	14.9	S16	A16	K16	AIR 16U-6	AIL 16U-6
<b>SIR 0025 R16UB-6</b>	25	29	200	17.4	S16	A16	K16	AIR 16U-6	AIL 16U-6

For **LEFT HAND** toolholders specify **SIL** instead of **SIR**